



waag society

institute for art, science and technology

BioHack Academy Sterile Hood Design



Working sterile

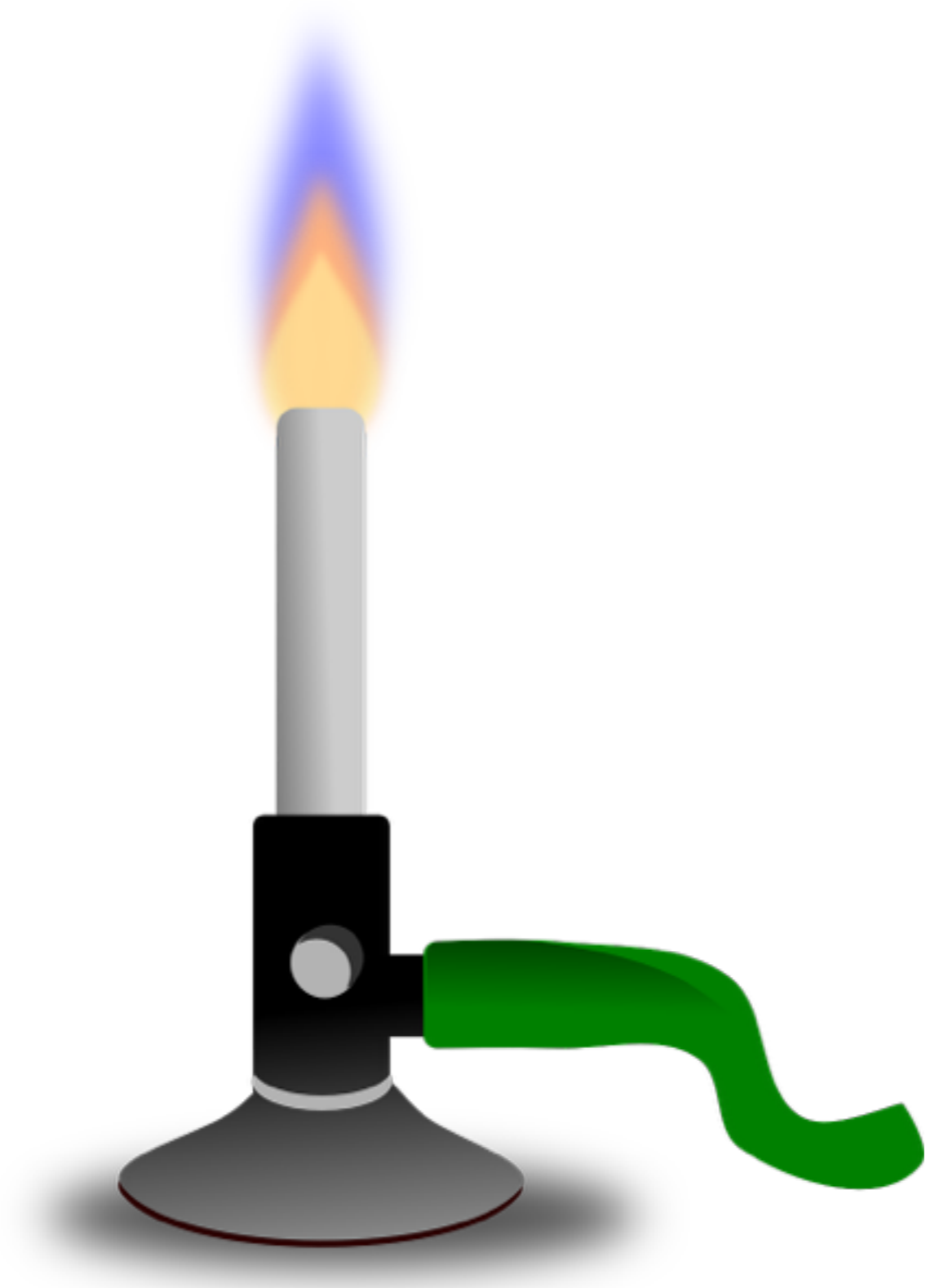



Sterile hoods



Public Domain



Rudolph Simon - CC-BY-SA 3.0



José Eugenio Gómez Rodríguez - CC-BY-SA 2.0

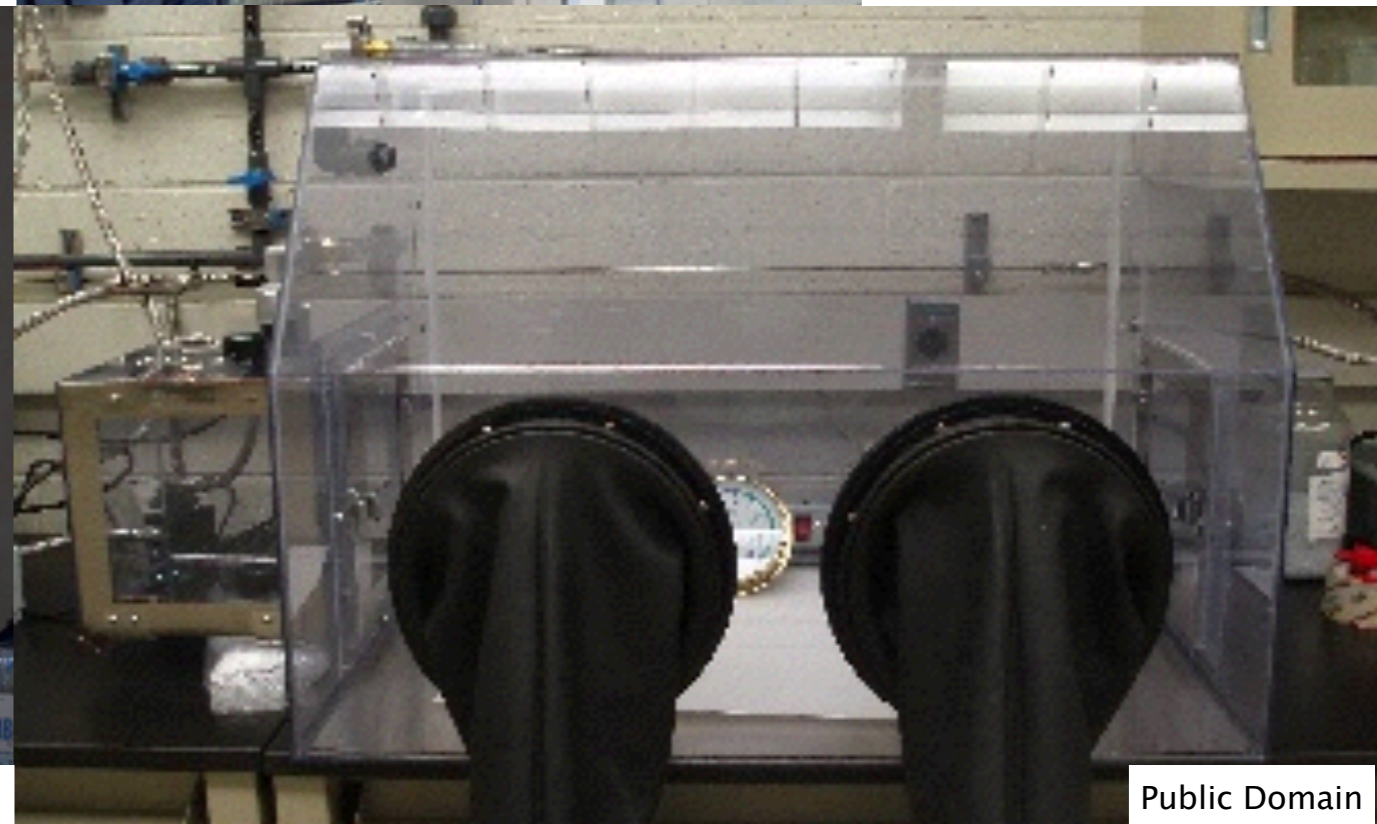

Public Domain



Components

- Pre filter
- Fan
- HEPA Filter
- Minimal air flow of 0.5 m / second

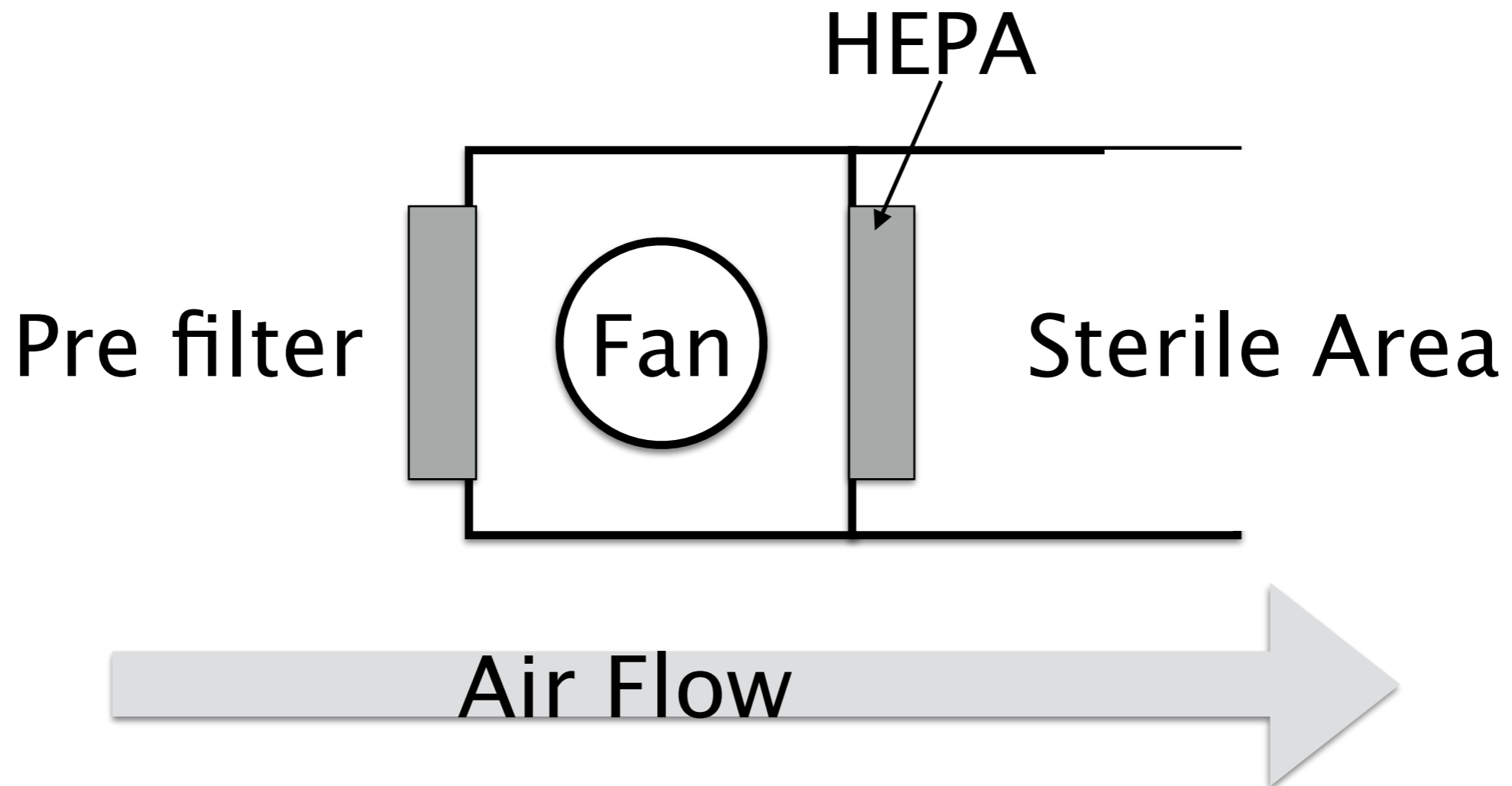



Horizontal vs Vertical airflow

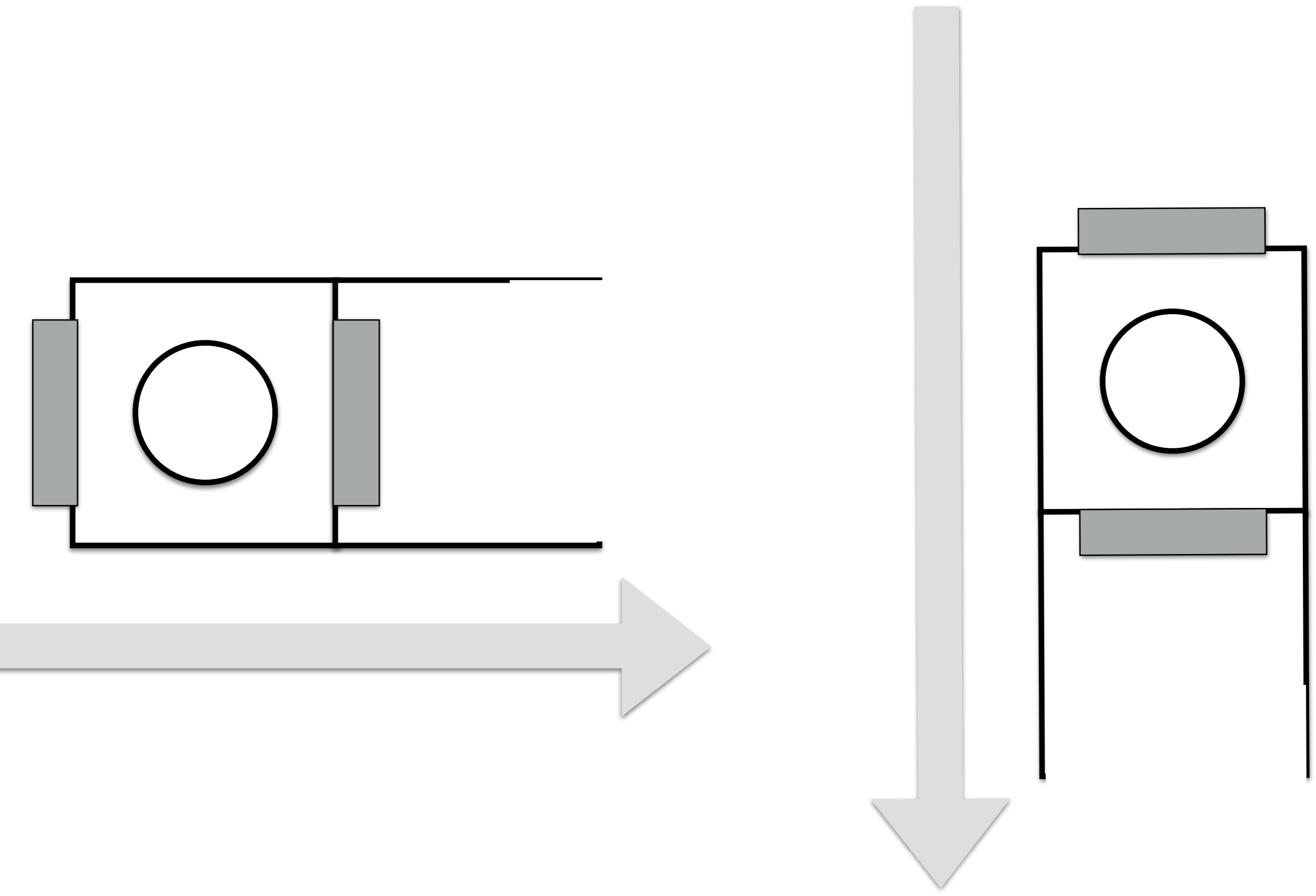



BioHack Academy 1 Design

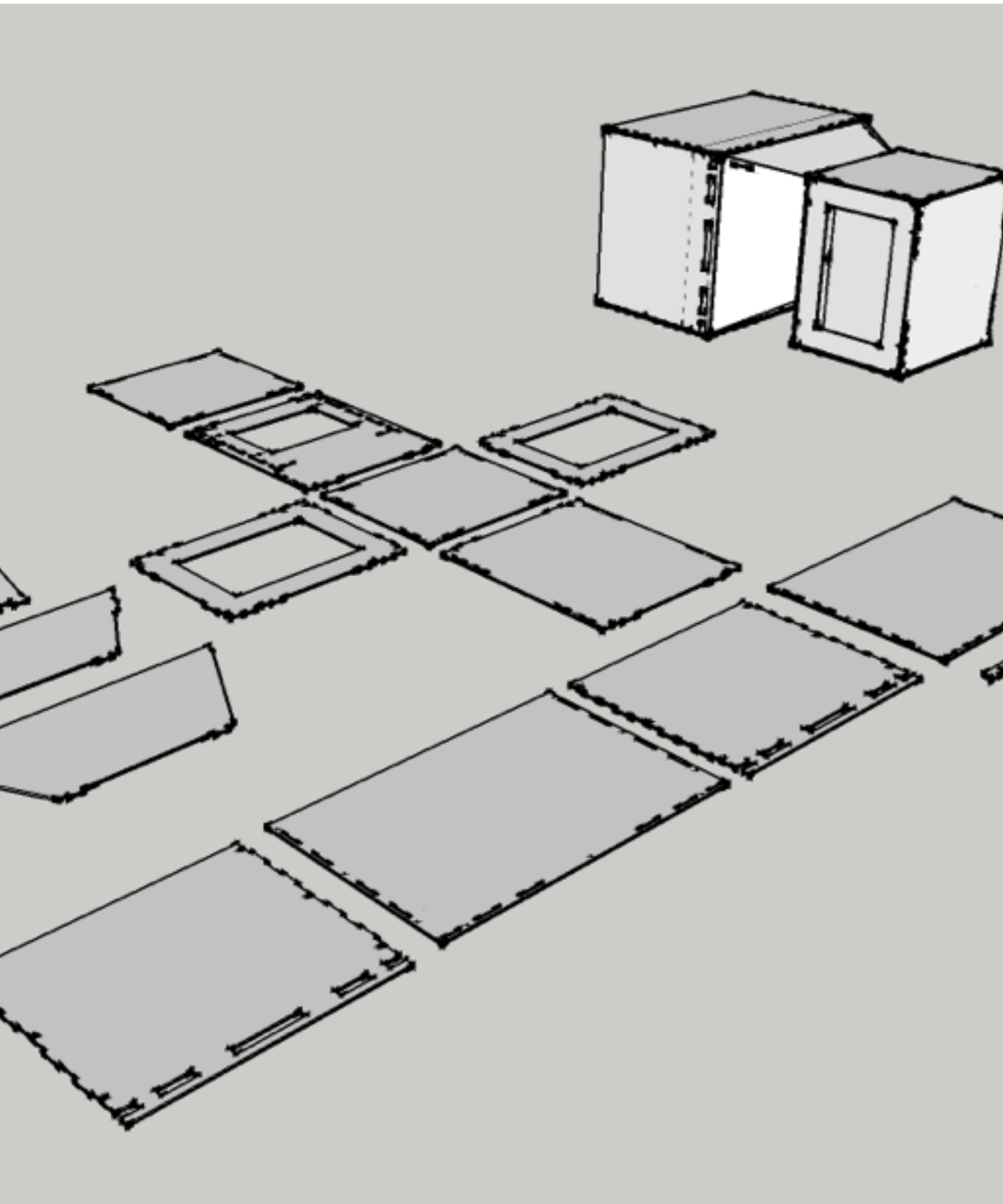



BioHack Academy 2 Design

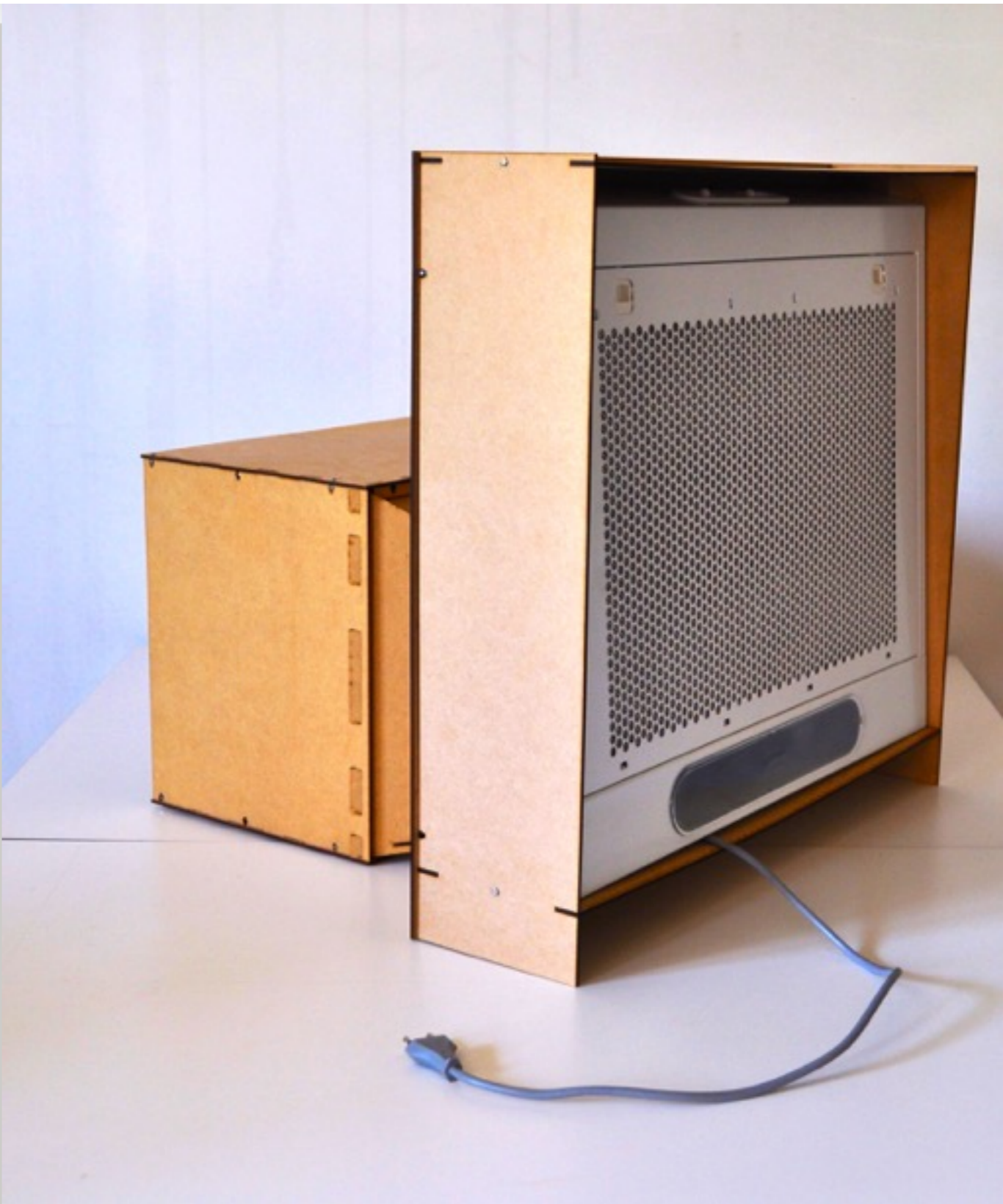
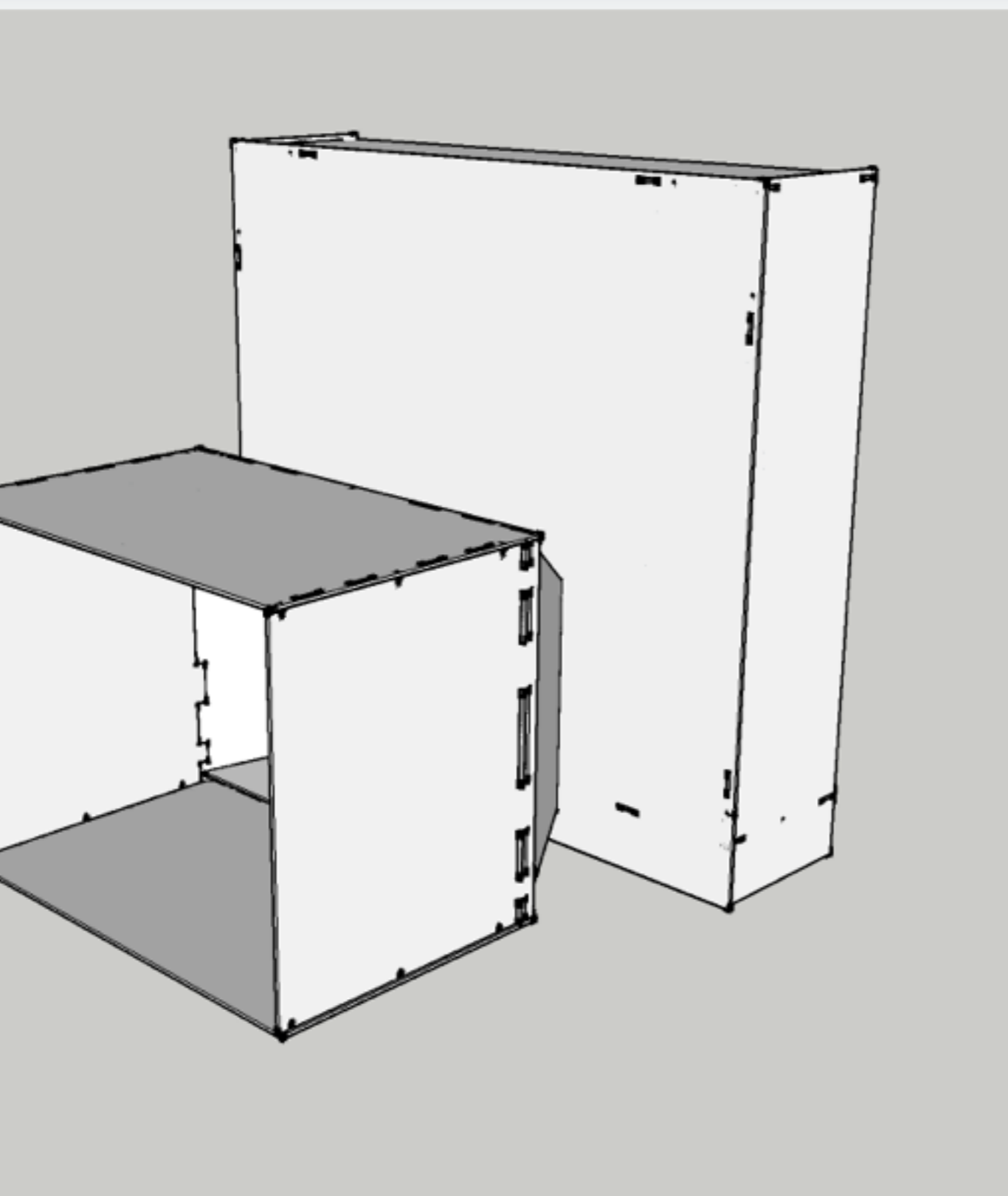



BioHack Academy 3 Design

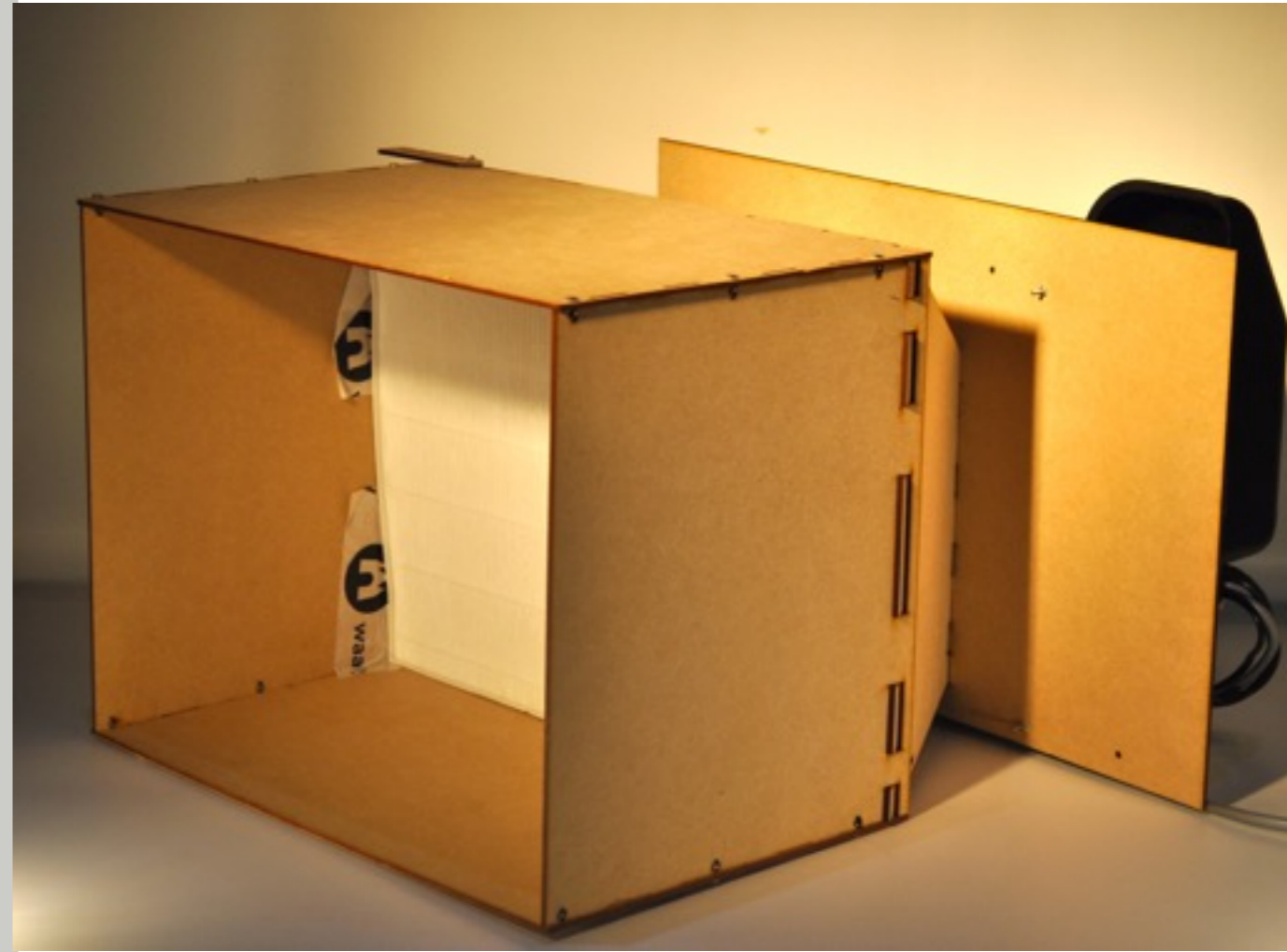
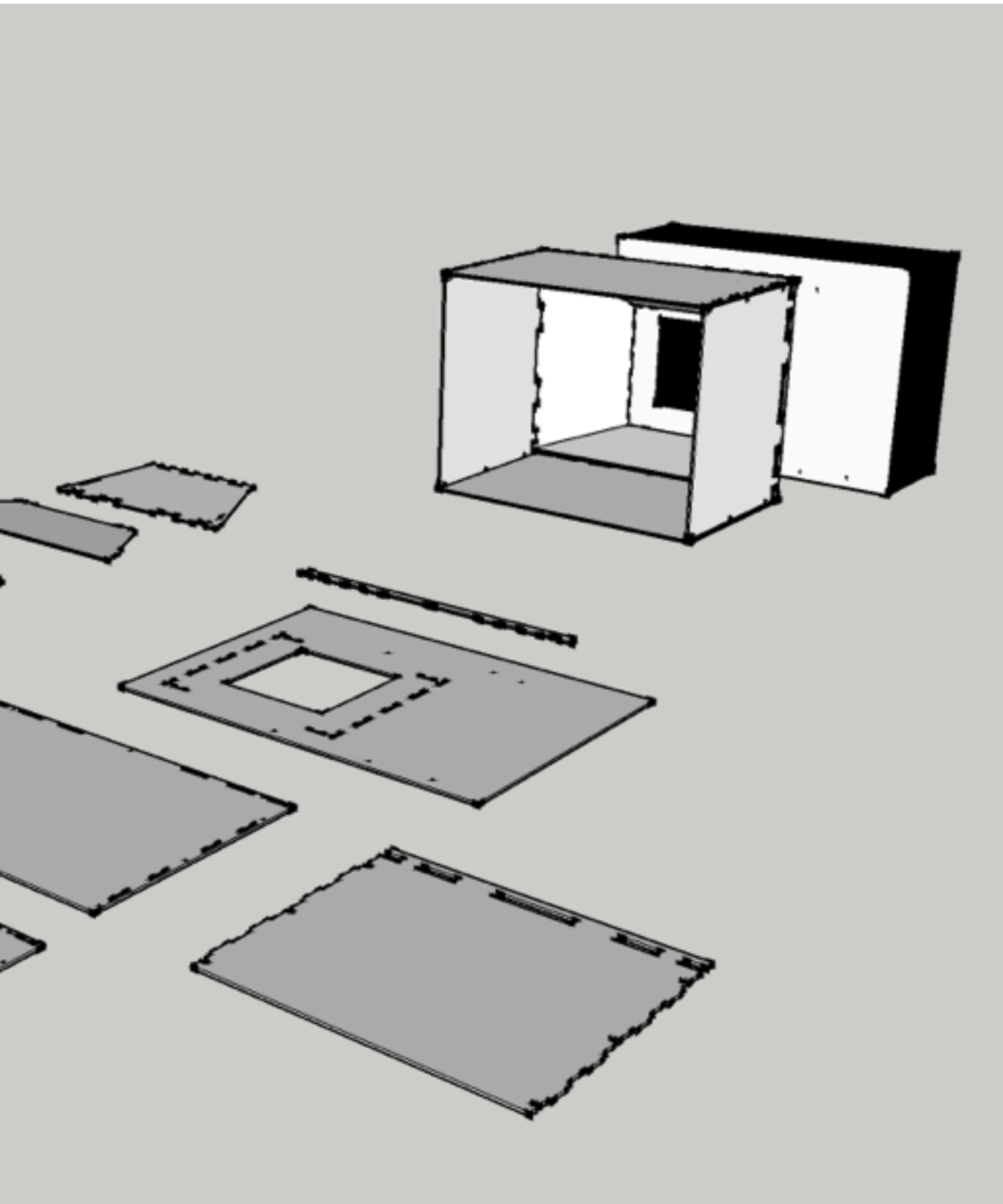



HEPA filter

- Fellowes office air filter
- 0.3 micron pores
- 99.97% filtering
- H14 class
 - EN1822 standard





Blower

- Calculate the airflow
- Needed:
 - $0.41 \times 0.32 \times 0.5 =$
 - 0.0656
 - cubic meter / second
 - 236.16
 - cubic meter / hour
- We choose 250 cubic meter / hour



IKEA

1 CFM = 1,6990 m³/h



Test results

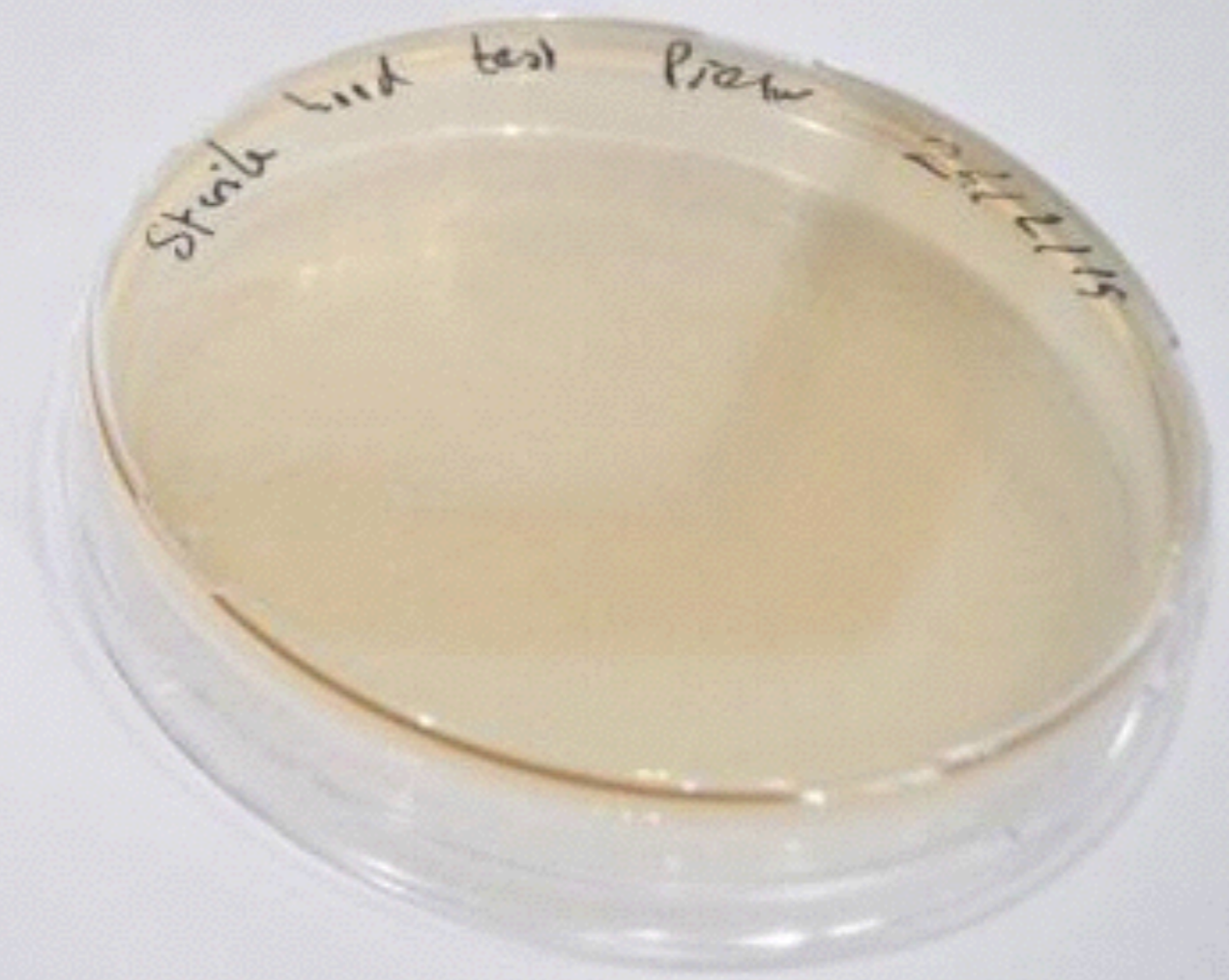
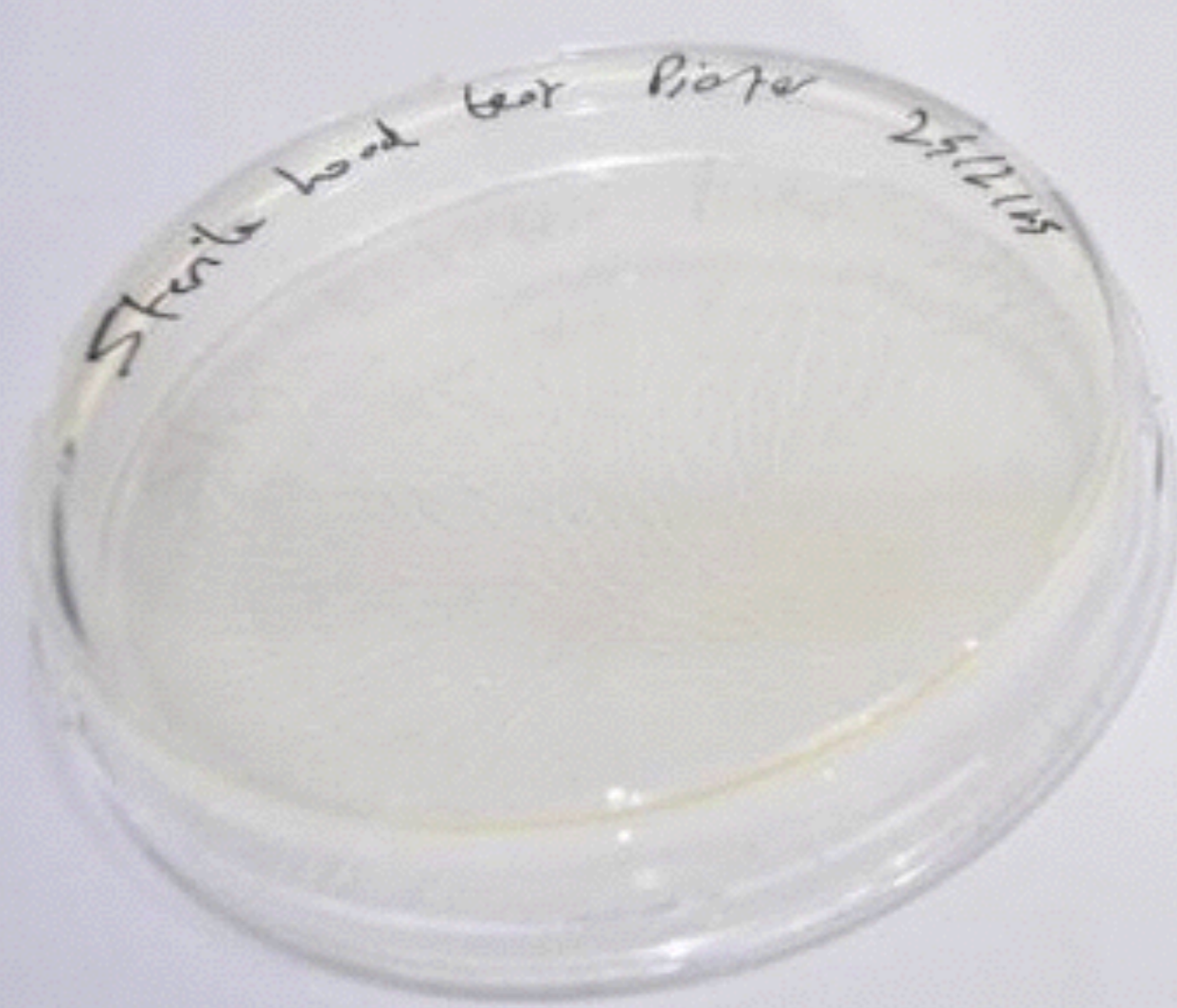



Schedule Monday / Tuesday

- Monday Morning:
 - 10:00 Lab Tour & Safety Demonstration
 - 13:00 FreeCAD 3D modeling workshop
- Tuesday:
 - 10:00 Principles of Electronics
 - 13:00 SketchUp modeling workshop
 - 15:00 Production and assembly of SterileHood



some

rights

reserved